

iCtP™

PlateWriter™ 2000

AFFORDABLE
EASY TO USE
CHEMISTRY-FREE

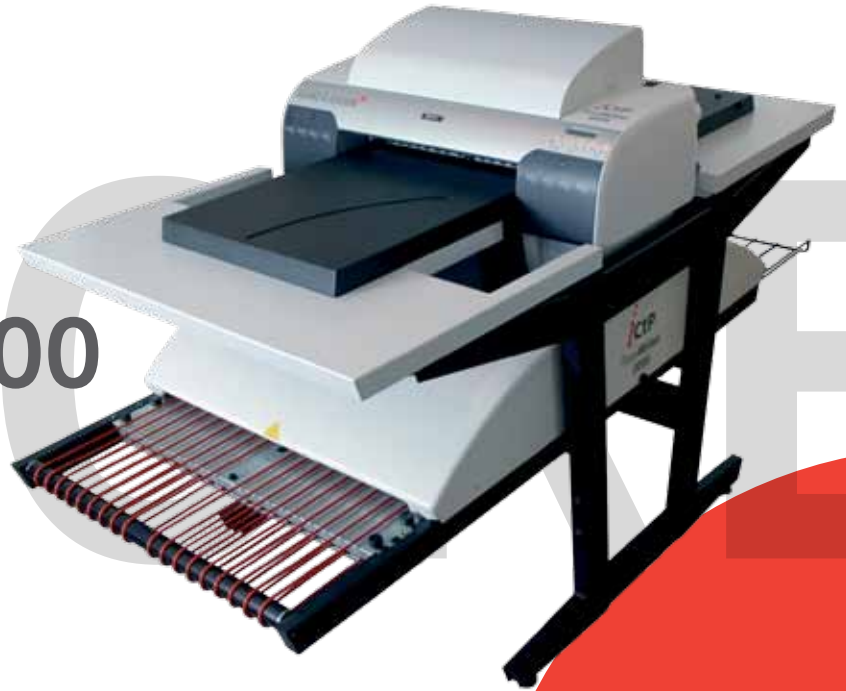

The PlateWriter™ 2000 is the second generation of Glunz & Jensen's acclaimed iCtP range of Computer-to-Plate systems, which produce press-ready aluminum plates without the use of chemical processing.

Setting new standards in cost flexibility and speed, the PlateWriter™ produces digital CtP plates, which delivers accurate registration and high quality for small to medium format offset printers.

The PlateWriter™ applies a patented Liquid Dot™ image on to non-photosensitive aluminum printing plates. The imaged plates are manually fed through an integrated finishing unit that dries the plates and bonds the liquid dots to the plate surface.

The finishing unit includes a built-in gumming station to finish the plates for storage or immediate use on press. The daylight operation and chemistry free approach makes iCtP the ideal low maintenance platemaking solution.



The PlateWriter™ 2000 features a semi-automatic plate alignment system to ensure accurate registration and transport through the imaging engine.



The use of advanced inkjet technology eliminates the use of any processing chemistry. No mess - no fuss.



The PlateWriter™ 2000 is powered by the industry standard Harlequin Postscript RIP accepting jobs from Mac or PC in Postscript, PDF, EPS, TIFF & JPEG formats - handling your job, ripping it and outputting it directly to the PlateWriter™.

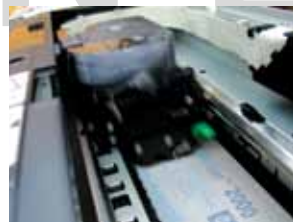

Easy to use – The conventionally grained aluminum plates are imaged in front of your eyes. The PlateWriter™ operates in normal daylight conditions and the plates require no pressroom changes.



Imaged plates are finished through the integrated Finishing Unit, located below the Print Engine, to finish the plates by bonding the liquid dots to the plate surface. The Finishing Unit includes an automatic gumming station which applies a protective gum layer.

GLUNZ & JENSEN 

PLATESETTING • ICTP

iCtP™ PlateWriter™ 2000

Technical specifications

Imaging device	1440 nozzle, delivering ultra high definition 2880 dpi
Imaging fluid	Patented Liquid Dot™ technology
Plate type	Uncoated grained and anodized aluminum plate, optimized for iCtP™ (All 1 and 2-up formats)
Plate thickness	Aluminum 0.15 - 0.20 mm (0.006 - 0.008")
Plate width	203 - 459 mm (8.0 - 18.1")
Plate length	279 - 610 mm (11.0 - 24.0")
Max imaging size (W x L)	432 x 610 mm (17.0 x 24.0")
Plate finishing	Automated integral gumming system
Imaging resolution	1440 x 1440 dpi or 2800 x 2800 dpi
Imaging speed	6 - 10 B3 plates/hour @ max resolution (Dependent on plate format and image coverage)
Run length	50,000 impressions
RIP	Harlequin based RIP platform: 2 GB RAM, 100 BaseT ethernet with connectivity to MAC and PC environments
Screening	Stochastic screening, optimized for iCtP™ ensuring moiré free prints
Power supply	100 to 230 VAC, 50/60 Hz
Power consumption	Stand by: 0.3 kW Process: 2.3 kW
Operating environment	Temperature range 15 - 32°C (59 - 90°F); 20°C (68°F) or higher recommended
Humidity range	35 to 80% (no condensation)
Footprint (L x W x H)	1942 x 884 x 1182 mm (76.4 x 34.8 x 46.5")
Weight	Crated: 271 kg (596 lbs) Non crated: 165 kg (363 lbs)
Standard equipment	PlateWriter high definition Inkjet Print Engine, finishing unit including baking, gumming and dryer system, feed and delivery table, stand for PlateWriter 2400, RIP workstation with Mac and PC connectivity, Harlequin based Xitron RIP with iScreening technology, basic colour proofing support for Epson 4800/4880, 7800/7880, 9800/9880, and fluid start-up kit.

NB: This brochure was printed on a Heidelberg® Speedmaster with plates created on a PlateWriter™ system.

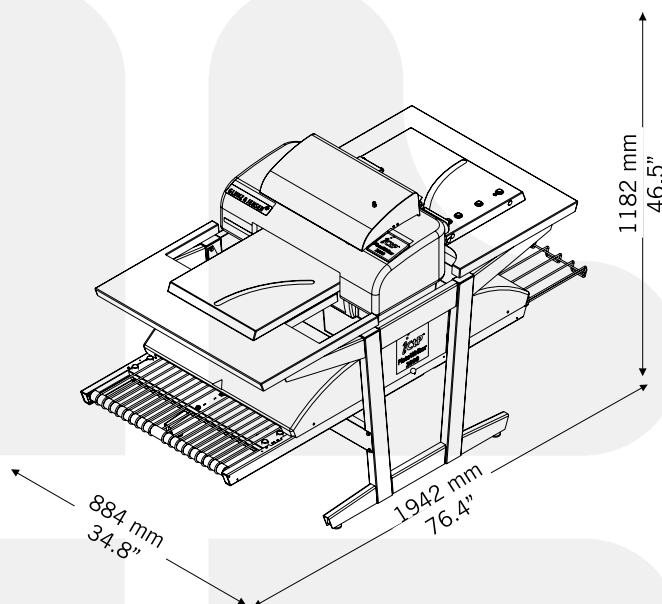

GLUNZ & JENSEN

Headquarters:
 Glunz & Jensen A/S
 Haslevvej 13
 DK-4100 Ringsted
 Denmark
 Tel. +45 57 68 81 81
 Fax +45 57 68 83 40
 ictp@glunz-jensen.com

Glunz & Jensen, Inc.
 12633 Industrial Drive
 Granger, IN 46530
 USA
 Tel. +1 574 272 9950
 Fax +1 574 277 6566
 ictp@glunz-jensen.com

www.platewriter.com